

Joyful Quilt



Joyful Quilt

Fabric Requirements

Skill Level: Beginner / Intermediate

Completed Quilt: 80" x 100"



DC7794 Bloom 1 Yard
GRANDIFLORA



DC7794 Garden 3/4 Yard
GRANDIFLORA



DC7794 Sprout 3/4 Yard
GRANDIFLORA



DC7795 Stone 3/4 Yard
GO YOUROWN WAY



DC7795 Teal 1/2 Yard
GO YOUROWN WAY



DC7796 Green 1/2 Yard
MASQUERADE



DC7796 Peach 3/4 Yard
MASQUERADE



DC7797 Garden 3/4 Yard
TAPESTRY



DC7797 Sprout 1/2 Yard
TAPESTRY



DC7798 Daisy 3/4 Yard
FULL BLOOM



DC7798 Flower 3/4 Yard
FULL BLOOM

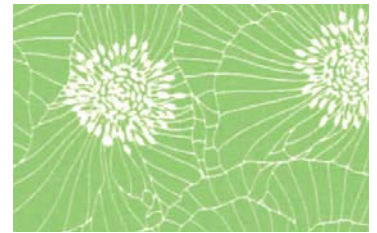

DC7798 Grass 3/4 Yard
FULL BLOOM



DC7799 Flower 3/4 Yard
SHAPE PARADE



DC7799 Water 1/2 Yard
SHAPE PARADE



DC7800 Daisy 1 Yard
LOST & FOUND



DC7800 Flower 3/4 Yard
LOST & FOUND



DC7801 Azalea 1/2 Yard
WHISP



DC7801 Clover 1/2 Yard
WHISP



BINDING FABRIC:
DC7798 Daisy 3/4 Yard
FULL BLOOM



BACKING FABRIC:
DC7794 Bloom 5 3/4 Yards
GRANDIFLORA



DC7800 Leaf 3/4 Yard
LOST & FOUND



SC5333 Starfruit 1/2 Yard
COTTON COUTURE

Joyful Quilt

Cutting Instructions:

- BINDING FABRIC - Cut 9 strips 2¼" x WOF. Set aside for binding.

- BACKING FABRIC - Cut 2 pieces 104" long. Set aside for backing.

- All other fabrics are cut into: **A** - 11" squares and **B** - 12" squares as per the table below.

Subcut each **A** square as per the above diagram, resulting in two 11" right-angles triangles.

Subcut each **B** 12" square as per the above diagram, resulting in two 6" right angled triangles & 2 trapeziums.

There will be some leftover pieces when squares are subcut.

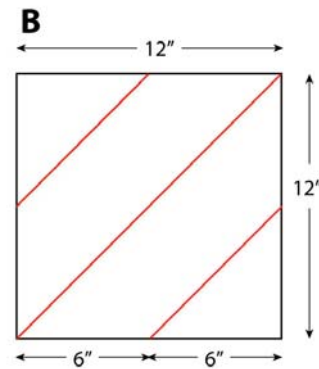
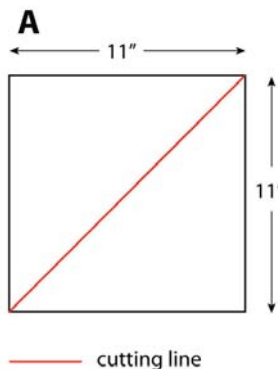

FABRIC	CUT 11" SQUARES	SUBCUT 11" TRIANGLES	CUT 12" SQUARES	SUBCUT 6" TRIANGLES	SUBCUT TRAPEZIUMS
1 - DC7794 Bloom	6	12	2	4	4
2 - DC7794 Garden	1	2	3	5	6
3 - DC7794 Sprout	3	6	2	4	4
4 - DC7795 Stone	2	3	3	2	6
5 - DC7795 Teal	1	2	2	4	4
6 - DC7796 Green	2	4	1	2	2
7 - DC7796 Peach	2	3	2	4	3
8 - DC7797 Garden	3	5	3	2	6
9 - DC7797 Sprout	1	2	2	4	3
10 - DC7798 Daisy	3	6	3	6	4
11 - DC7798 Flower	2	3	3	6	6
12 - DC7798 Grass	3	5	2	4	3
13 - DC7799 Flower	2	4	2	2	4
14 - DC7799 Water	1	2	2	4	4
15 - DC7800 Daisy	3	6	4	7	5
16 - DC7800 Flower	2	3	3	6	4
17 - DC7801 Azalea	1	2	4	8	4
18 - DC7801 Clover	2	3	1	2	2
19 - DC7800 Leaf	2	3	2	4	4
20 - SC5333 Starfruit	1	2	2	4	2

Joyful Quilt

Also Needed:

- 84" x 104" quilt batting.
- A rotary cutter, a long acrylic ruler, a large square acrylic ruler, while not essential, will make your life easier (10½" or larger), a cutting mat, thread, scissors, pins.

Construction:

* All seam allowances are 1/4".

* Many seams in this quilt are along bias cut edges of fabric and thus will have a tendency to be easily stretched if pulled. To avoid this problem, do not pull fabrics while sewing.

- Layout quilt according to the **Quilt Layout** diagram on the following page.

- Sew blocks according to the following instructions & diagrams, **C & D**.

- **C:** When using two 11" triangles, place fabrics right sides together (RST) & sew along long diagonal edge. Press seam open. Square up your finished square to 10½" x 10½", keeping the seam line directly in the centre.

- **D:** When using 6" triangles & trapeziums, place the triangle, RST on the trapezium, matching the long diagonal edge of the triangle to the short diagonal edge of the trapezium. Sew along this edge. Press seam open. Square up resulting triangle so that each perpendicular side measures 11", keeping the seam line at exactly 45°, and the small triangle measures 5½" along its sides. Then use this squared up triangle as you would an 11" triangle in step **C**.

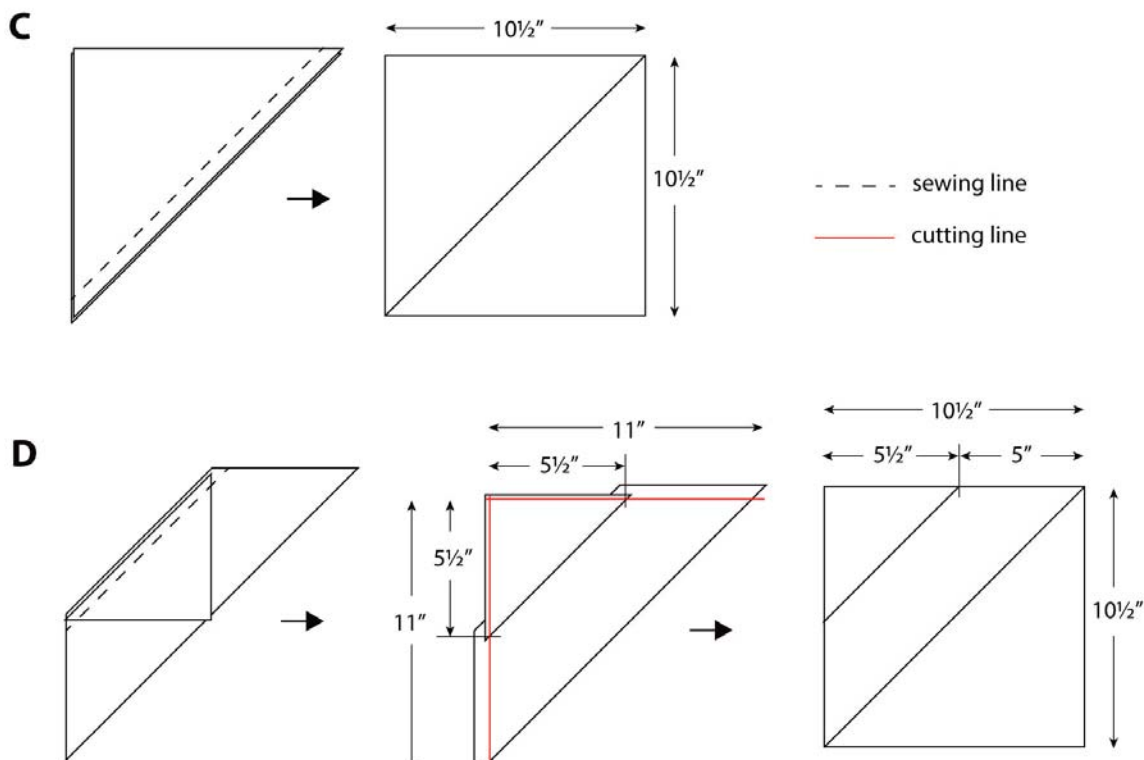

Piecing Quilt Top:

Sew the blocks together, one row at a time. Press seams open. Pin rows together, matching seam lines and corners. Sew rows together. Press seams open.

Assembling Quilt:

Sew together two backing pieces along the long edges. Press seam open. Layer backing, batting and quilt top. Baste or pin. Quilt as desired. Square up quilt top. Join binding strips together and bind in your preferred fashion.

Joyful Quilt

Quilt Layout

Numbers refer to the fabric numbers in the Cutting Chart

