

# MERRY OLE LONDON

SIZE: 56" W x 62" H • LEVEL: INTERMEDIATE • PATTERN BY: NATALIE CRABTREE • CITY OF LONDON FABRIC COLLECTION  
PATTERN AVAILABLE ON: [WWW.MICHAELMILLERFABRICS.COM](http://WWW.MICHAELMILLERFABRICS.COM)



THIS IS A DIGITAL REPRESENTATION OF THE QUILT TOP, FABRIC MAY VARY.

**PLEASE NOTE:** BEFORE BEGINNING YOUR PROJECT, CHECK FOR ANY PATTERN UPDATES AT [MICHAELMILLERFABRICS.COM](http://MICHAELMILLERFABRICS.COM)'S FREE PROJECTS SECTION.

# MERRY OLE LONDON

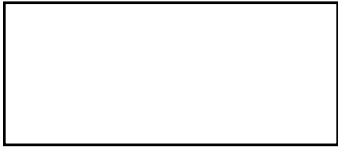

**FABRIC A**  
Cotton Couture  
SC\_5333 Bright White  
2 1/4 yards

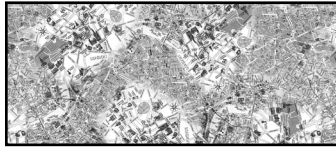

**FABRIC B**  
DCX11668  
London Map Silver  
5/8 yard



**FABRIC C**  
DCX11669 - Changing  
of the Guard Multi  
1/2 yard



**FABRIC D**  
DCX11670  
City Lights Silver  
3/8 yard



**FABRIC E**  
DCX11672  
City Streets Brick  
3/8 yard



**FABRIC F**  
DCX11674  
Union Jack Royal  
3/8 yard



**FABRIC G**  
CX11675  
Windsor Plaid Red  
5/8 yard

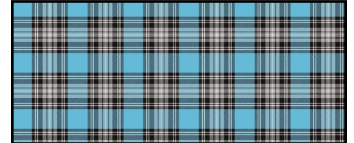

**FABRIC H**  
CX11675  
Windsor Plaid Blue  
3/8 yard



**FABRIC I**  
CX11675  
Windsor Plaid Silver  
3/8 yard

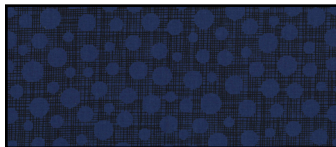

**FABRIC J**  
CX6699  
Hash Dot Midnite  
1 1/2 yards  
(includes binding)

**BACKING:**  
3 3/4 yards

**BATTING:**  
64" x 70"



# MERRY OLE LONDON

WOF = Width of Fabric, RST = Right Sides Together, SNF = Stitch and Flip

*Designer Note: Some fabrics are directional prints. For most fabrics, general Cutting Instructions are provided, and are given Width X Height. To maintain directional prints, reference the quilt image on the cover and Block Assembly on Pages 5-8 before cutting. Ensure that prints will be oriented as you desire before cutting. Ample yardage has been required to accommodate directional prints and some fussy cutting. You may opt to lay out cutting before proceeding to ensure efficient use of yardage.*

*It is recommended to divide cut pieces by the block type.*

KEY	CUTTING INTRUCTIONS
A	<ul style="list-style-type: none"> <li>• Cut (4) 3" x WOF strips. Subcut the following for Large Star Blocks:               <ul style="list-style-type: none"> <li>○ (16) 3" x 5 1/2" rectangles.</li> <li>○ (16) 3" squares.</li> </ul> </li> <li>• Cut (3) 1 1/2" x WOF strips. Subcut the following for Small Star Blocks:               <ul style="list-style-type: none"> <li>○ (24) 1 1/2" x 2 1/2" rectangles.</li> <li>○ (24) 1 1/2" squares.</li> </ul> </li> <li>• Cut (1) 2" x WOF strip. Subcut (4) 2" x 4 1/2" rectangles for Small Star Blocks.</li> <li>• Cut (1) 1 1/2" x WOF strip. Subcut (2) 1 1/2" x 15 1/2" rectangles for Small Star Blocks.</li> <li>• Cut (12) 1" x WOF strips. Subcut the following for assorted Letter Blocks:               <ul style="list-style-type: none"> <li>○ (12) 1" x 14 1/2" rectangles.</li> <li>○ (12) 1" x 15 1/2" rectangles.</li> </ul> </li> <li>• Cut (1) 10 1/2" x WOF strip. Subcut the following:               <ul style="list-style-type: none"> <li>○ (1) 10 1/2" square for the "L" Letter Block.</li> <li>○ (2) 5" x 4 1/2" rectangles for the "O" Letter Blocks.</li> <li>○ (1) 7 1/2" x 6 1/2" rectangle for the "D" Letter Block.</li> </ul> </li> <li>• Cut (1) 4" x WOF strip. Subcut (10) Curved Template A. Turn the template 180° after each cut to best utilize fabrics. You can keep the WOF strip folded to make less cuts.</li> <li>• Cut (1) 6 1/2" x WOF strip. Subcut (4) "N" Letter Block Template A. Turn the template 180° after each cut to best utilize fabrics. <b>Unfold the WOF strip to avoid making 'mirror image' templates.</b></li> <li>• Cut (3) 3 1/2" x WOF strips. Piece strips for length using diagonal seams to make (1) long strip. Subcut (2) 3 1/2" x 50 1/2" strips for Quilt Assembly.</li> <li>• Cut (6) 1 1/2" x WOF strips. Piece strips for length using diagonal seams to make (1) long strip. Subcut the following for Quilt Assembly:               <ul style="list-style-type: none"> <li>○ (2) 1 1/2" x 56 1/2" Side Inner Borders.</li> <li>○ (2) 1 1/2" x 52 1/2" Top/Bottom Inner Borders.</li> </ul> </li> </ul>
B	<ul style="list-style-type: none"> <li>• Cut (6) 2 1/2" x WOF strips. Piece strips for length using diagonal seams to make (1) long strip. Subcut the following for Quilt Assembly:               <ul style="list-style-type: none"> <li>○ (2) 2 1/2" x 58 1/2" Side Outer Borders.</li> <li>○ (2) 2 1/2" x 56 1/2" Top/Bottom Outer Borders.</li> </ul> </li> </ul>
C	<ul style="list-style-type: none"> <li>• Cut (2) 14 1/2" x 5 1/2" rectangles for the "O" Letter Blocks.</li> <li>• Cut (2) 5 1/4" x 4 1/2" rectangles for the "O" Letter Blocks.</li> <li>• Cut (4) 1" squares for the "O" Letter Blocks.</li> </ul>



# MERRY OLE LONDON

<b>D</b>	<ul style="list-style-type: none"><li>• Cut (1) 4 ½" x 14 ½" rectangle for the "D" Letter Block.</li><li>• Cut (2) 10 ½" x 4" rectangles for the "D" Letter Block.</li><li>• Cut (1) 4 ½" x 7 ½" rectangle for the "D" Letter Block.</li><li>• Cut (2) 1" squares for the "D" Letter Block.</li></ul>
<b>E</b>	<ul style="list-style-type: none"><li>• Cut (2) 4 ½" x 14 ½" rectangles for the "N" Letter Blocks.</li><li>• Cut (1) "N" Letter Block Template B for the "N" Letter Blocks.</li></ul>
<b>F</b>	<ul style="list-style-type: none"><li>• Cut (1) 4 ½" x 10 ½" rectangle for the "L" Letter Block.</li><li>• Cut (1) 14 ½" x 4 ½" rectangle for the "L" Letter Block.</li></ul>
<b>G</b>	<ul style="list-style-type: none"><li>• Cut (1) 5 ½" x WOF strip. Subcut the following:<ul style="list-style-type: none"><li>○ (4) 5 ½" squares for Large Star Blocks.</li><li>○ (6) 2 ½" squares for Small Star Blocks.</li></ul></li><li>• Cut (4) 3" x WOF strips. Subcut (48) 3" squares for Large Star Blocks.</li></ul>
<b>H</b>	<ul style="list-style-type: none"><li>• Cut (2) 14 ½" x 5 ½" rectangles for the "O" Letter Blocks.</li><li>• Cut (2) 5 ¼" x 4 ½" rectangles for the "O" Letter Blocks.</li><li>• Cut (4) 1" squares for the "O" Letter Blocks.</li></ul>
<b>I</b>	<ul style="list-style-type: none"><li>• Cut (2) 4 ½" x 14 ½" rectangles for the "N" Letter Blocks.</li><li>• Cut (1) "N" Letter Block Template B for the "N" Letter Blocks.</li></ul>
<b>J</b>	<ul style="list-style-type: none"><li>• Cut (7) 2 ¼" x WOF strips for binding.</li><li>• Cut (1) 5 ½" x WOF strip. Subcut (6) 5 ½" squares for Large Star Blocks.</li><li>• Cut (8) 3" x WOF strips. Subcut the following for Large Star Blocks:<ul style="list-style-type: none"><li>○ (24) 3" x 5 ½" rectangles.</li><li>○ (56) 3" squares.</li></ul></li><li>• Cut (2) 1 ½" x WOF strips. Subcut (48) 1 ½" squares for Small Star Blocks.</li></ul>

# MERRY OLE LONDON

## Large Star Block Assembly:

1. Draw a diagonal line on the wrong side of (48) 3" Fabric G squares.
2. Place (1) 3" Fabric G square onto the corner of (24) 5 1/2" x 3" Fabric J rectangles, RST and edges aligned. Note the orientation of the drawn diagonal line in the diagram.
3. Sew along the drawn diagonal line on each square/rectangle combination. Then, trim excess corner fabric to a 1/4". Press toward the corners.
4. Repeat SNF techniques described in Steps 2-3 to attach (1) 3" Fabric G square to the adjacent corner of each 5 1/2" x 3" Fabric J rectangle to create (24) Flying Geese Units measuring 5 1/2" x 3" unfinished.

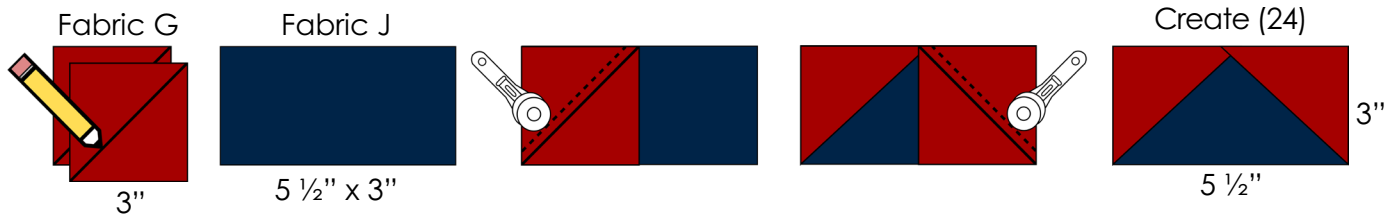

5. Arrange (4) Flying Geese Units created in Steps 1-4 with (1) 5 1/2" Fabric J square and (4) 3" Fabric J squares to form (1) Large Star Block.
6. Sew together, pressing seams away from the Flying Geese Units. The Large Star Block should measure 10 1/2" x 10 1/2" unfinished.
7. Repeat to create a total of (6) Large Star Blocks using the colorway shown in Steps 1-6.

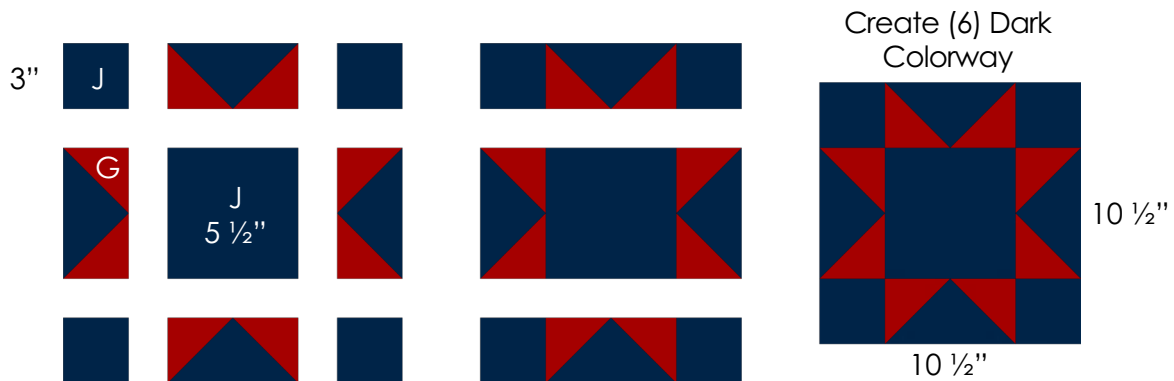

8. Draw a diagonal line on the wrong side of (32) 3" Fabric J squares. Use squares in Step 9.
9. Repeat Large Star Block assembly to create an additional colorway. Use 3" Fabric J squares, 5 1/2" Fabric G squares, 3" Fabric A squares and 5 1/2" x 3" Fabric A rectangles. Reference the diagram for the location of fabrics.
10. Repeat to create a total of (4) Large Star Blocks using the colorway shown in Steps 8-9.

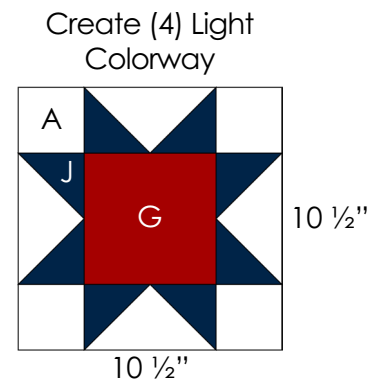

# MERRY OLE LONDON

## Small Star Block Assembly:

11. Draw a diagonal line on the wrong side of (48) 1 1/2" Fabric J squares. Use squares in Step 12.
12. Use the same techniques described in the Large Star Block Assembly section to make (6) Small Star Units. Use 1 1/2" Fabric J squares, 2 1/2" Fabric G squares, 1 1/2" Fabric A squares and 2 1/2" x 1 1/2" Fabric A rectangles. Reference the diagram for the location of fabrics. Small Star Units should measure 4 1/2" x 4 1/2" unfinished.

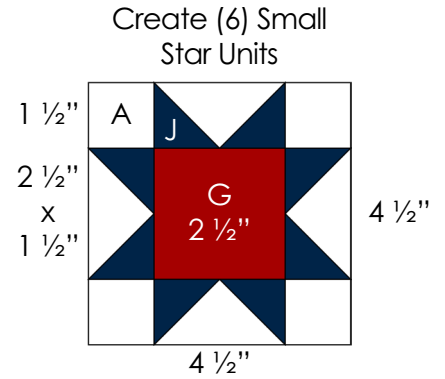

13. Arrange (3) Small Star Units with (2) 4 1/2" x 2" Fabric A rectangles and (1) 1 1/2" x 15 1/2" Fabric A rectangle to form (1) Complete Small Star Block.
14. Sew together, pressing seams away from the Small Star Units. The Complete Small Star Block should measure 5 1/2" x 15 1/2" unfinished.
15. Repeat to make a total of (2) Complete Small Star Blocks referencing Steps 13-14.

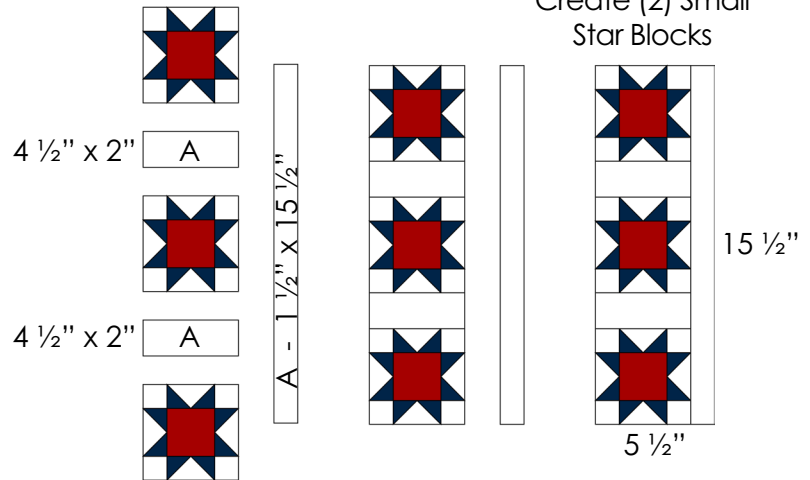

## "L" Letter Block Assembly:

16. Arrange (1) 4 1/2" x 10 1/2" Fabric F rectangle, (1) 14 1/2" x 4 1/2" Fabric F rectangle, (1) 10 1/2" Fabric A square, (2) 1" x 14 1/2" Fabric A rectangles and (2) 1" x 15 1/2" Fabric A rectangles to form (1) "L" Letter Block.
17. Sew together, pressing seams toward Fabric F and toward the thin outer Fabric A rectangles. The "L" Letter Block should measure 15 1/2" x 15 1/2" unfinished. Only (1) "L" Letter Block is required.

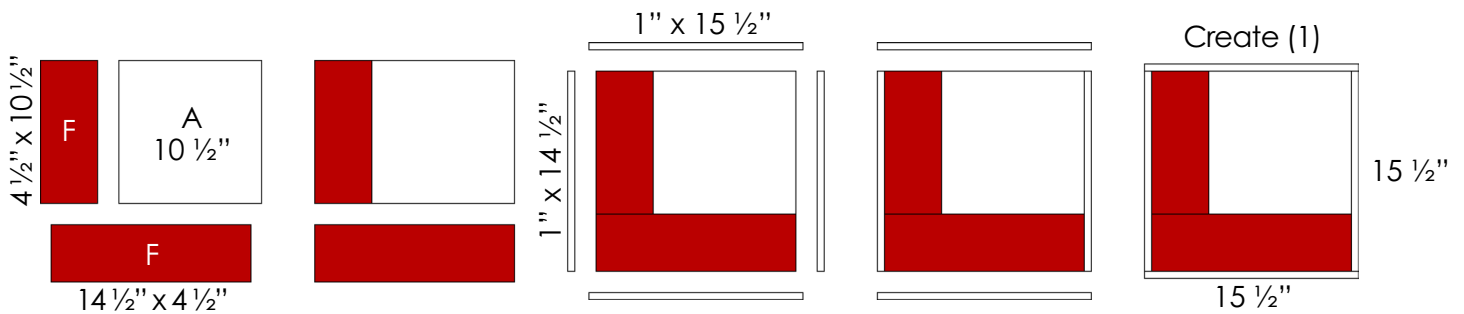

# MERRY OLE LONDON

## “O” Letter Block Assembly:

*Designer Note: The “O” and “D” Letter Blocks use unique curved piecing assembly. You may opt to test the methods using scrap fabric before using methods on your actual project.*

18. Draw a diagonal line on the wrong side of (4) 1" Fabric C squares.
19. Repeat SNF techniques to attach (1) 1" Fabric C square to each corner of (1) 5" x 4 1/2" Fabric A rectangle. The SNF Unit should measure 5" x 4 1/2" unfinished.

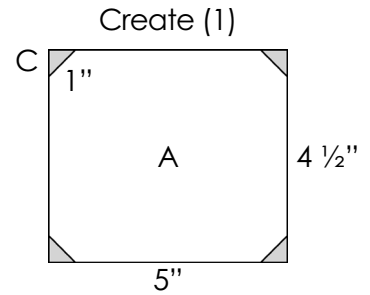

20. Place the paper Curved Template B onto the corner of (1) 14 1/2" x 5 1/2" Fabric C rectangle so that the template curve is facing the top left corner of the Fabric C rectangle and the edges of the template are aligned with the raw edges of the Fabric C rectangle. Reference the diagram. Pin in place if necessary.
21. Trim the corner of the Fabric C rectangle using Curved Template B as a guide. The corner of the Fabric C rectangle should now be a curve.
22. Leaving Curved Template B in place, make a small mark on the curved corner of the Fabric C rectangle where the diagonal line is on the Curved Template B using an erasable marker or pen. This will help align curved templates accurately for piecing.
23. Repeat to trim the adjacent corner of the Fabric C rectangle as shown in the diagram.
24. Repeat to trim a total of (2) 14 1/2" x 5 1/2" Fabric C rectangles.

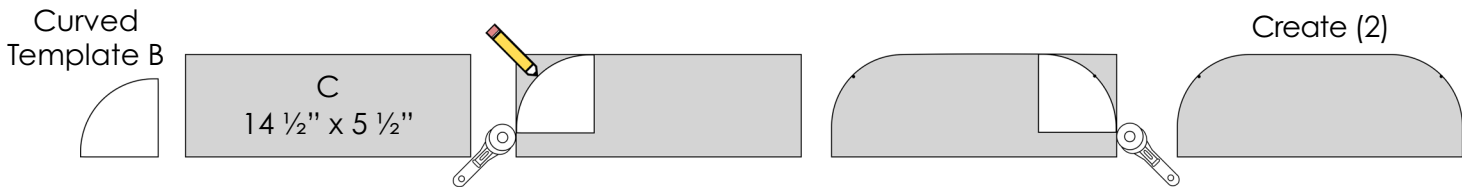

25. Fold (10) Fabric A Curved Template A in half as shown in the diagram and lightly press using a hot iron. The crease will help align curved templates accurately for piecing. (Some Fabric A Curved Template A won't be used until “D” Letter Block Assembly.)

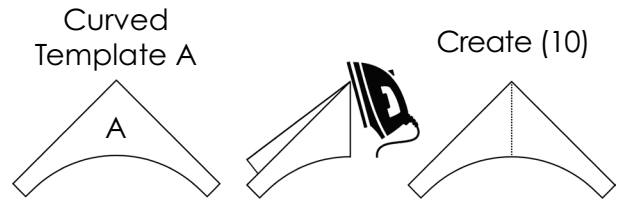

26. Place the trimmed corner of the Fabric C rectangle with (1) Fabric A Curved Template A, RST. Align the mark made in Step 22 with the pressed crease in the Fabric A piece and pin together. Then continue pinning until all edges are secure.
27. Sew curved pieces together slowly using a slightly smaller stitch length and in the needle down position. Stop frequently to realign and readjust fabrics as needed. Continue sewing until the curved pieces are sewn together. Press outward and check for puckers or inaccuracies.

28. Repeat to attach (1) Fabric A Curved Template A to the other trimmed corner of the Fabric C rectangle. Then, ensure the completed Curved Unit measures 14 1/2" x 5 1/2" unfinished.

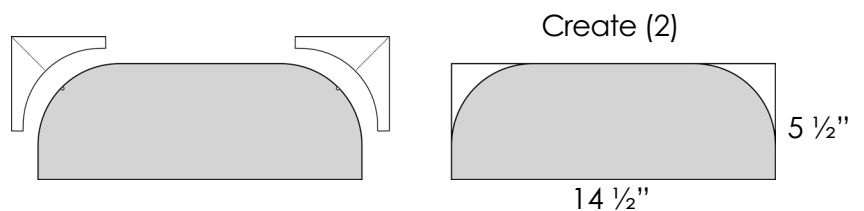

29. Repeat to create a total of (2) Curved Units.

# MERRY OLE LONDON

30. Arrange the SNF Unit, (2) Curved Units, (2) 5 ¼" x 4 ½" Fabric C rectangles, (2) 1" x 14 ½" Fabric A rectangles and (2) 1" x 15 ½" Fabric A rectangles to form (1) "O" Letter Block.
31. Sew together, pressing seams toward Fabric C and toward the thin outer Fabric A rectangles. The "O" Letter Block should measure 15 ½" x 15 ½" unfinished.
32. Repeat Steps 18-31 to make (1) additional colorway. Use Fabric H "O" Letter pieces and Fabric A.

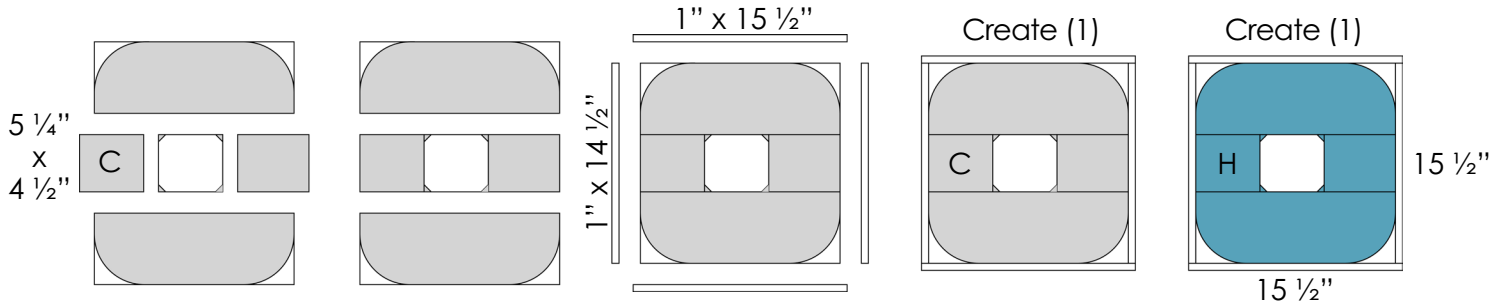

## "N" Letter Block Assembly:

33. Arrange (2) 4 ½" x 14 ½" Fabric E rectangles, (1) Fabric E "N" Letter Block Template B, (2) Fabric A "N" Letter Block Template A, (2) 1" x 14 ½" Fabric A rectangles and (2) 1" x 15 ½" Fabric A rectangles to form (1) "N" Letter Block.
34. Sew together, pressing seams toward Template A pieces, toward the Fabric E rectangles and toward the thin outer Fabric A rectangles. When piecing templates, align the blunted edges and use pins for accuracy. The "N" Letter Block should measure 15 ½" x 15 ½" unfinished.
35. Repeat Steps 33-34 to make (1) additional colorway. Use Fabric I "N" Letter pieces and Fabric A.

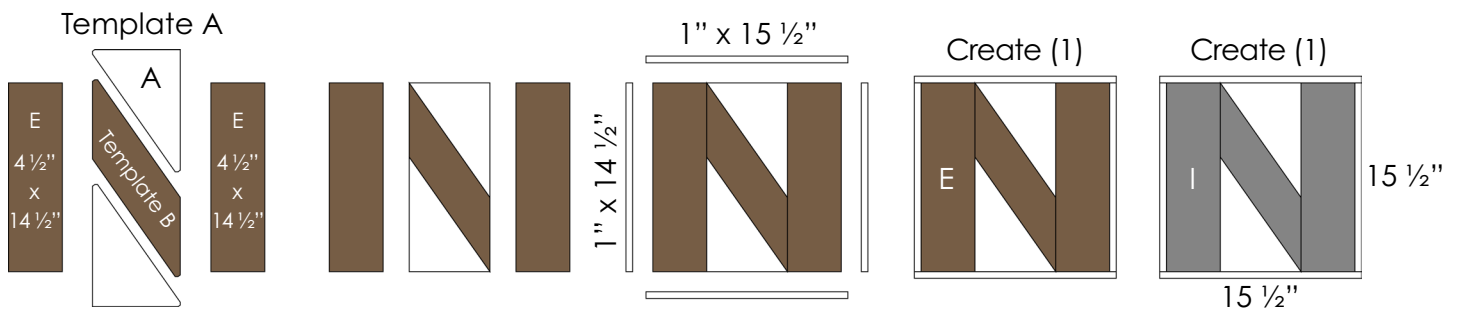

## "D" Letter Block Assembly:

36. Draw a diagonal line on the wrong side of (2) 1" Fabric D squares.
37. Repeat SNF techniques to attach (1) 1" Fabric D square to the top right and bottom right corners of (1) 6 ½" x 7 ½" Fabric A rectangle. Reference the diagram for the orientation of the Fabric A rectangle. The SNF Unit should measure 6 ½" x 7 ½" unfinished.

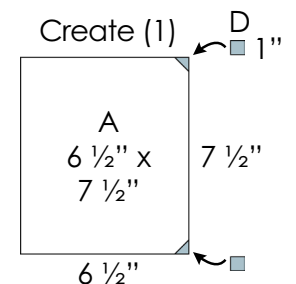

38. Repeat corner trimming techniques described in Steps 20-22 to trim the top right corner of (1) 10 ½" x 4" Fabric D rectangle and the bottom right corner of (1) 10 ½" x 4" Fabric D rectangle.
39. Repeat curved piecing techniques described in Steps 26-27 to attach (1) Fabric A Curved Template A prepared in Step 25 to the trimmed corners of both Fabric D rectangles. The Curved Units should measure 10 ½" x 4" unfinished.



# MERRY OLE LONDON

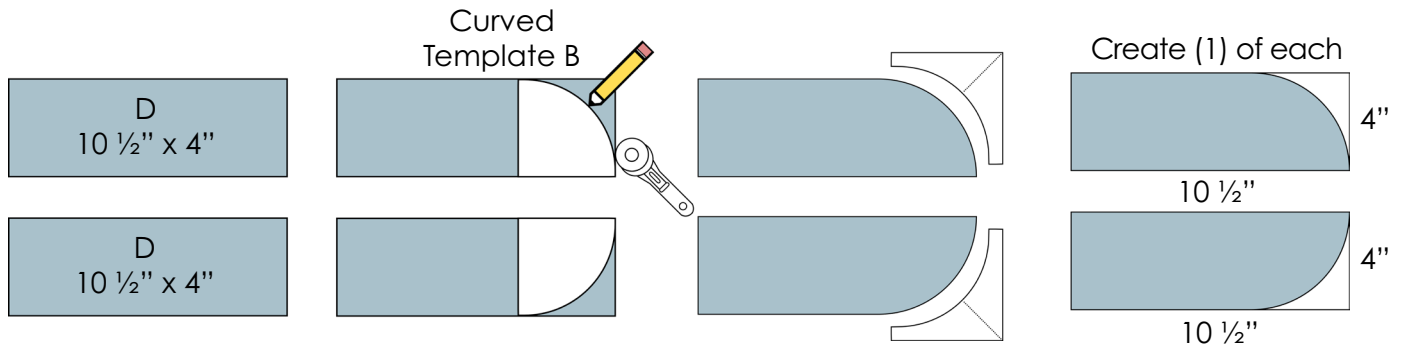

40. Arrange (1) SNF Unit, (2) Curved Units, (1)  $4\frac{1}{2}$ " x  $14\frac{1}{2}$ " Fabric D rectangle, (1)  $4\frac{1}{2}$ " x  $7\frac{1}{2}$ " Fabric D rectangle, (2)  $1$ " x  $14\frac{1}{2}$ " Fabric A rectangles and (2)  $1$ " x  $15\frac{1}{2}$ " Fabric A rectangles to form (1) "D" Letter Block.

41. Sew together, pressing seams toward Fabric D and toward the thin outer Fabric A rectangles. The "D" Letter Block should measure  $15\frac{1}{2}$ " x  $15\frac{1}{2}$ " unfinished. Only (1) "D" Letter Block is required.

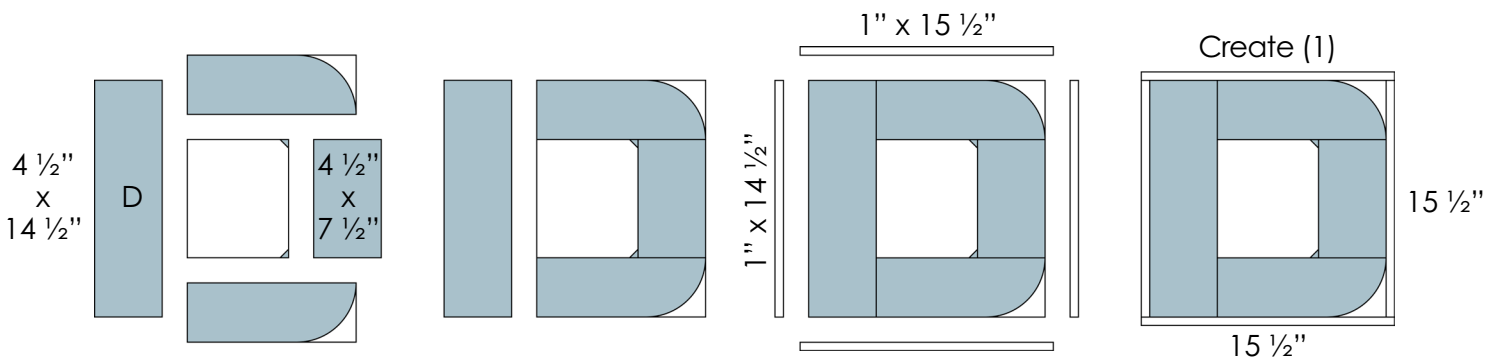

## Quilt Assembly:

42. Arrange Large Star Blocks, Complete Small Star Blocks, all Letter Blocks and (2)  $50\frac{1}{2}$ " x  $3\frac{1}{2}$ " Fabric A strips to form the quilt top center.

43. Sew together, using pins to align the blocks for accuracy. The quilt top center should measure  $50\frac{1}{2}$ " x  $56\frac{1}{2}$ " unfinished.

44. Attach Fabric A Inner Borders and Fabric B Outer Borders. Reference the diagram and the Cutting Instructions for the measurement of each border. For each set of borders, attach Side Borders first followed by Top/Bottom Borders. Press away from the quilt top center. Once complete, the quilt top should measure  $56\frac{1}{2}$ " x  $62\frac{1}{2}$ " unfinished.

# MERRY OLE LONDON

B - 2 1/2" x 56 1/2"



A - 1 1/2" x 52 1/2"

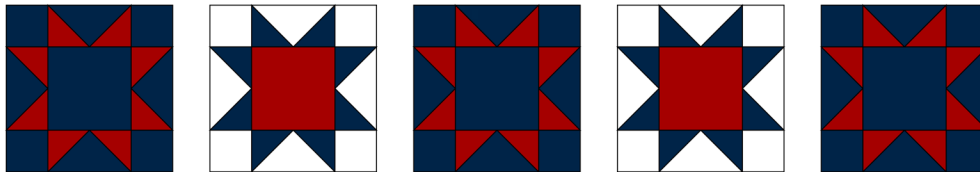

A - 50 1/2" x 3 1/2"

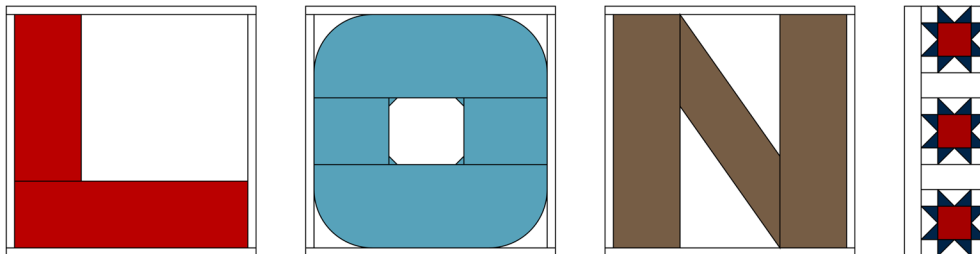
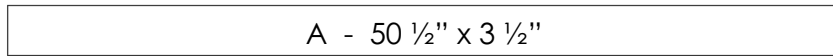

B - 2 1/2" x 58 1/2"

A - 1 1/2" x 56 1/2"

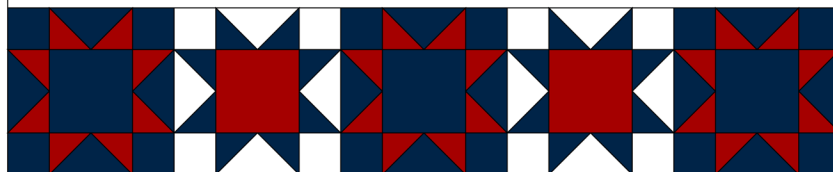
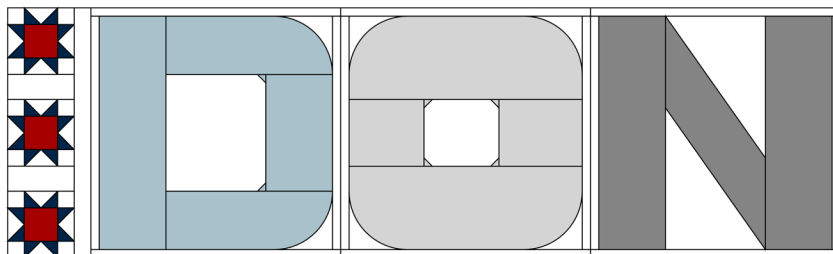
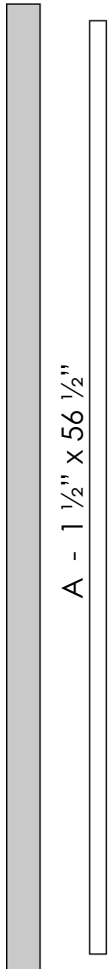

## Finishing the Quilt:

45. Sandwich the quilt top with batting and backing. Baste quilt layers together using your preferred method.
46. Quilt as desired.
47. Bind quilt using (7) 2 1/4" x WOF Fabric J strips.

# MERRY OLE LONDON TEMPLATES

“N” Letter Block Template A

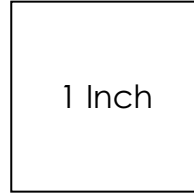

Print at 100% or  
Actual Size

“N” Letter Block Template B  
1 of 2

Join

# MERRY OLE LONDON TEMPLATES

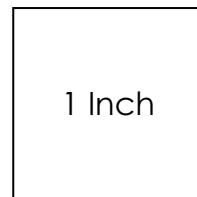
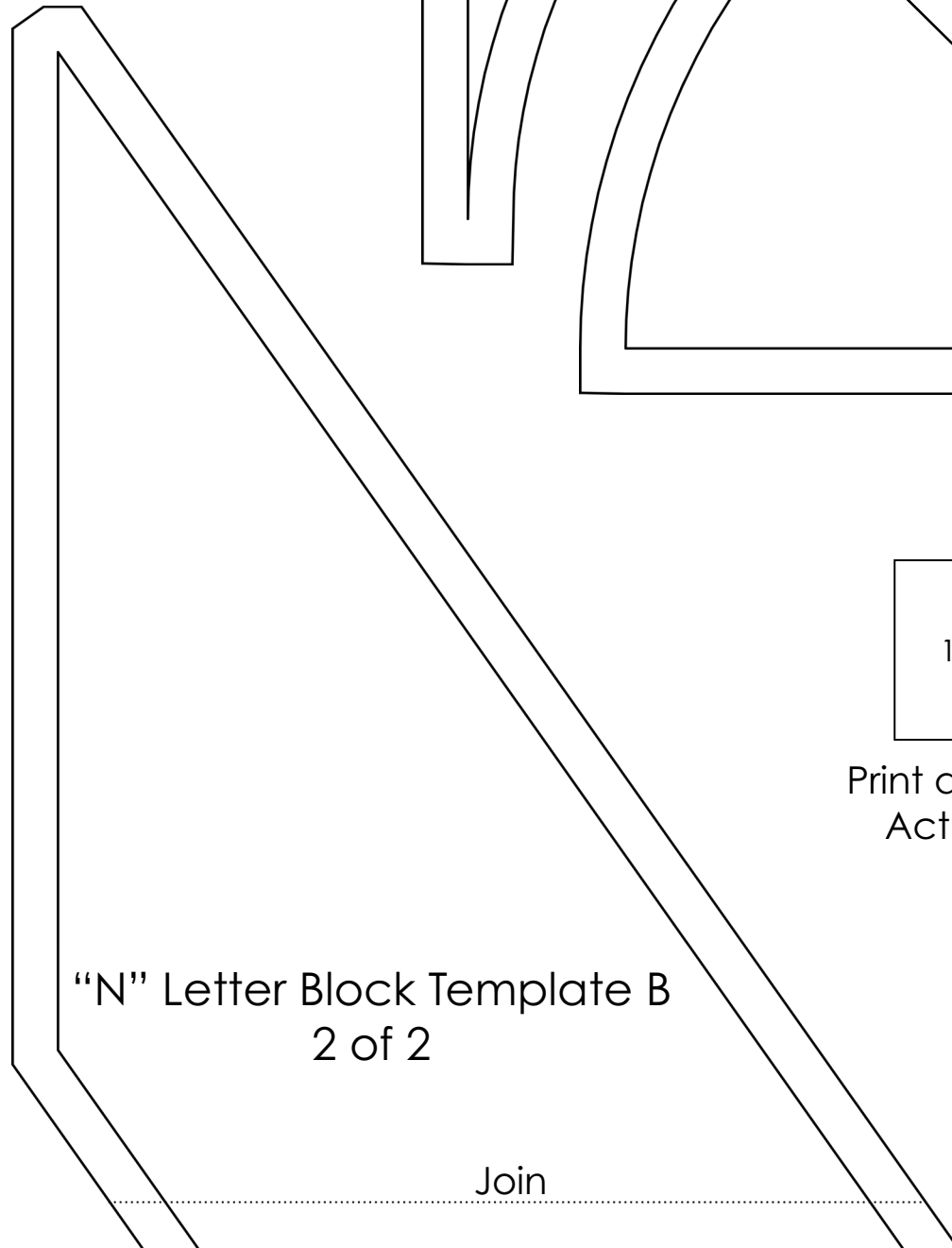
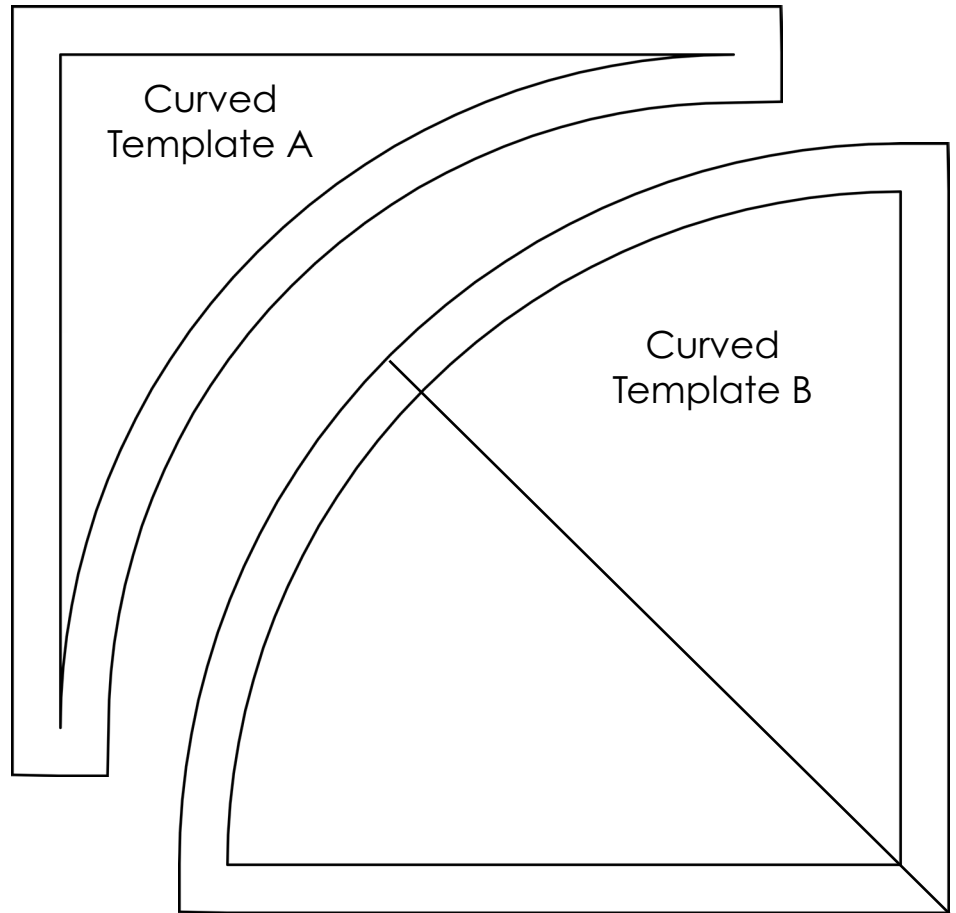

Print at 100% or  
Actual Size